

PANORAMIC P38.13

- ▶ **Kubota Tier III Engine**, 100Horsepower
- ▶ **Cabin is largest in market** providing excellent 360 degree visibility
- ▶ **Boom sideshift system** allows loads to be placed more accurately
- ▶ **Front stabilisers independently controlled**, improves machine stability

SINCE 1964



Merlo's unique design ensures good weight balance, comfort efficiency and agility



PANORAMIC P38.13

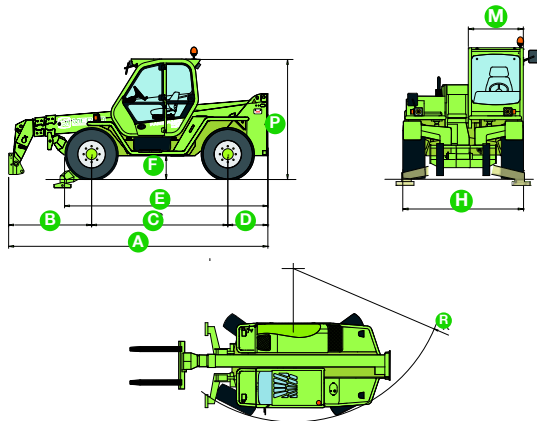

DIMENSIONS

A (mm)	5,240
B (mm)	1,675
C (mm)	2,750
D (mm)	815
E (mm)	4,100
F (mm)	480
H (mm)	2,220
M (mm)	995
P (mm)	2,440
R (mm)	3,920

PERFORMANCE

Unladen Weight (kg)	8,650
Maximum Load Capacity (kg)	3,800
Maximum Lift Height (m)	12.6
Capacity at Maximum Height (kg)	3,000
Maximum Reach (m)	8.8
Capacity at Maximum Reach (kg)	700
Boom Side-Shift (mm)	±340
Frame Levelling (%)	±10

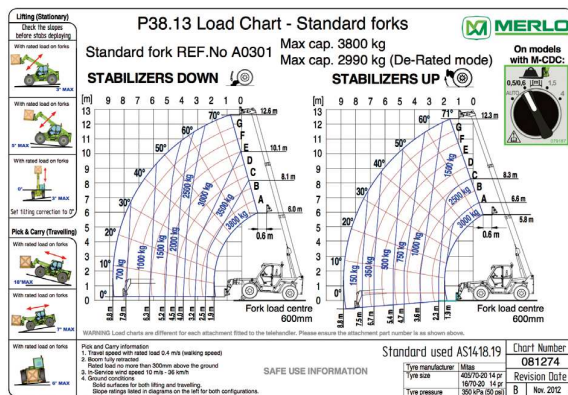

STANDARD SPECIFICATIONS

Engine

Turbo Engine	Kubota V3800 Euro III
Range/Cylinders	3800/4
Engine Power (kW/HP)	74/100
Maximum Speed (km/h)	40
Fuel Tank Capacity (l)	140

Transmission

Hydrostatic Merlo Transmission	Std
Speeds	2
Dual Reverse Shuttle System	Std
Pedal Inching-Control	Std
Permanent Four-Wheel Drive	Std

Brakes

Automatic Parking Brake	Std
External Dry Disc Service Brakes	Std

Tyres

Standard Tyres	405/70-20
----------------	-----------

Cab

Air Conditioned Cabin	Std
Air Suspension Seat	Std
FOPS (ISO 3449) and ROPS (ISO 3471) Cab	Std

Steering

All Wheel Steering	Std
--------------------	-----

Instruments

Electromechanical Joystick Control	Std
Merlo Dynamic Load Control (M-CDC)	Std
Reversing Camera	Std

Hydraulic System-Implement

Load-Sensing Hydraulic System (bar-l/min)	210-115
Hydraulic Oil Tank Capacity (l)	105
Auxiliary Hydraulic Service on Boom	Std

Accessories and Attachments

Tac-Lock Attachment Locking	Std
Standard Forks	Std
Fork Extensions	Optional
Digging Bucket	Optional
Re-Handling Bucket	Optional
4 x 1 Bucket	Optional
Crane Hook	Optional
Reduced Height Crane Jib	Optional
Drum Clamp	Optional
Fork Rotator	Optional
Man Platform	Optional
Carriage with Floating Forks	Optional

EXTRA SPECIFICATIONS

Stabilisers	Std
Boom Side Shift	Std
Frame Levelling	Std



120-124 Toongabbie Road Girraween 2145 NSW Australia
For further information please call 1300 657 325 or visit merloaustralia.com.au

Merlo reserves the right to modify and update the contents of this document at any time. Information and technical data are as available at time of printing.

For current information on Merlo products please contact your Merlo dealer.

ABN 87116110751 MER-P38.13-2018